

# Assembly Instructions

# Solid State Electronic MYSTIFIER

2-P

EC-700

## PARTS LIST

| Price Each |   | Parts Supplied  |
|------------|---|---|
| \$ .10     | 6 | 3.3 MEGOHM RESISTORS R1, R2, R3, R4, R5, R6 (ORANGE-ORANGE-GREEN) (01218) |
| .50        | 6 | NE-2E NEON BULBS (09202)  |
| .50        | 9 | 0.25 uf CAPACITORS C1, C2, C3, C4, C5, C6, C7, C8, C9 (02307)*            |
| 1.50       | 1 | PRINTED CIRCUIT BOARD (82543)   |
|            | 1 | HOOKUP WIRE   |
|            | 1 | SET MOUNTING HARDWARE   |

Minimum Charge For Replacement Parts \$1.00. Remittance Must Be Made With Order. Specify Description And Part Number. Prices Subject To Change Without Notice.

\*Typical value

## INTRODUCTION

If you are a beginner, a satisfying, educational and rewarding experience is in store for you. EICOCRAFT introduces you to the exciting world of electronics, by acquainting you with actual electronic parts, and by building a professional printed circuit assembly. In the process of building, you will be going through exactly the same experiences as professional kit-builders or electronic engineers do - you will be reading professional instructions and illustrations; identifying, connecting and soldering professional parts. The EICOCRAFT instructions will guide you step-by-step all the way. When you finish the last step, you will have completed nothing less than a professional electronic assembly of the most modern type. Most EICOCRAFT projects use solid-state components (called transistors.) You will then be in a position to put the assembly to many versatile end uses, as we will describe later. So proceed carefully. You will enjoy as you learn. And will have the personal satisfaction of a professional task well done.

If you are a sophisticate, you will find EICOCRAFT kits excellent for those quick around-the-house projects you always wanted to do but didn't have the time to shop for parts. You'll also find that all EICOCRAFT kits are useful assemblies providing utility, as well as personal satisfaction in building. Versatility is a basic characteristic of these kits. You'll see that each EICOCRAFT kit lends itself to a variety of final applications; and also, that many projects are expandable by adding kits together.

You can also always be sure of top quality. EICOCRAFT is an original exclusive concept and product line designed and manufactured in the U.S.A. by EICO - the same company famous for 20 years of leadership in creative electronics.

Copyright 1966 EICO Electronic Instrument Co., Inc.

## GENERAL CONSTRUCTION HINTS

1. Install components FLUSH with the COMPONENT MOUNTING side of the board (see figures 1A and 2) and leads protruding from the COPPERFOIL SIDE.
2. OBSERVE POLARITY as shown when installing capacitors.
3. CUT the protruding leads 1/4" from the board and BEND back FLUSH with the COPPERFOIL SIDE. (See figure 1A).
4. Position the tip of your soldering iron at the junction of the lead and COPPERFOIL SIDE and apply solder. Quickly remove your soldering iron after the solder flows around the connection. USE HEAT AND SOLDER SPARINGLY TO AVOID DAMAGE TO THE BOARD OR COMPONENTS. CAUTION: SOLDERING IRON TIP SHOULD BE BRIGHT AND CLEAN, WATTAGE 37 WATTS, SOLDER ROSIN CORE ONLY. (See figure 1B).
5. Additional insulated hookup wire will be necessary for components remotely mounted from the printed circuit board depending upon your individual installation requirements. (See figure 4).

FIGURES 1A & 1B MOUNTING AND SOLDERING COMPONENTS

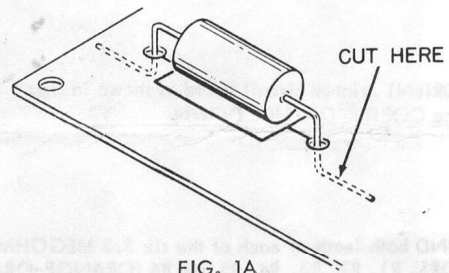

FIG. 1A

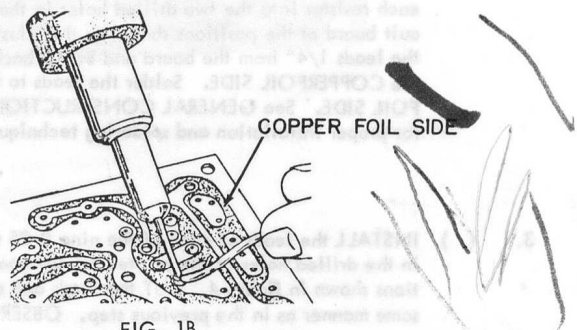

FIG. 1B

## Component Mounting

Figure 2 shows component mounting and mounting of the completed printed circuit board to the optional case using the mounting hardware supplied.

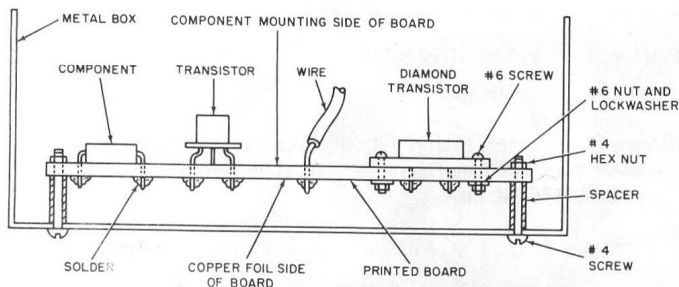

Figure 2. Component Mounting, Side View

## ASSEMBLY PROCEDURE

Assemble your EICOCRAFT kit as follows using figure 3 on the opposite page. A white number in a black circle adjacent to a component is the number of the corresponding step in which the component is installed. After you have completed each step, make a checkmark or cross out the number next to the step so that you will have a record of your work.

1. ( ) ORIENT printed circuit board as shown in figure 3 with the COPPERFOIL SIDE DOWN.
2. ( ) BEND both leads of each of the six 3.3 MEGOHM RESISTORS, R1, R2, R3, R4, R5 and R6 (ORANGE-ORANGE GREEN) at right angles to the body. INSERT the leads of each resistor into the two drilled holes in the printed circuit board at the positions shown on the illustration. CUT the leads 1/4" from the board and BEND back FLUSH with the COPPERFOIL SIDE. Solder the leads to the COPPERFOIL SIDE. See GENERAL CONSTRUCTION HINTS for proper installation and soldering techniques.
3. ( ) INSTALL the leads of each of the nine 0.25 uf CAPACITORS\* in the drilled holes of the printed circuit board at the positions shown in figure 4. CUT the leads and solder in the same manner as in the previous step. OBSERVE POLARITIES.

\*Typical Value

4. ( ) INSTALL the leads of each of the six NE-2E NEON BULBS in the drilled holes of the printed circuit board shown in figure 3. EXTENSION LEADS may be used if a different pattern of flashing is desired. CUT the leads and solder in the same manner as in the preceding steps. (See figure 3).
5. ( ) PREPARE two pieces of insulated wire (not supplied). CUT to the desired lengths. Actual length depends upon the distance for remotely mounted components (see figure 4). STRIP 1/4" of insulation from each of the two colored leads. PUSH the bare end of each wire through the applicable hole in the printed circuit board from the component side. BEND the lead flush with the COPPERFOIL SIDE and solder.

## CHECKING YOUR WORK

Check that each soldered connection is bright and clean, and that solder is not bridged across conductors on the foil side of the board. Make sure that the polarities of all the capacitors have been observed.

## OPERATION AND MOUNTING OF YOUR COMPLETED KIT

Connect a 90-volt battery to the printed circuit board leads A and B as shown in figure 4. An ON-OFF switch may be connected between the negative side of the battery and lead B. The completed kit and external circuit can be mounted in a compact metal cabinet. When the leads are connected to the battery, the pattern of lights will begin to blink at various intervals. Fig. 5 shows the schematic diagram for your kit.



APPLICATIONS

The EICOCRAFT EC-700 MYSTIFIER is the ideal gift for the "craftsman who has everything." The flashing of its six neon bulbs can be formed and re-formed into many impressive and bizarre geometric patterns. The near hypnotic effect of its dancing lights will rivet your attention for long periods of time, producing a soothed, relaxed state to all observers.

Nine capacitors, six resistors, and six neon bulbs, neatly arranged on a lightweight, easy-to-handle circuit board, create a rapidly moving, kaleidoscopic display of light energy. The Mystifier will stimulate the curiosity of any onlooker; whether used as a tranquilizer or as a conversation piece, the fascination it arouses will make the EICOCRAFT EC-700 MYSTIFIER one of your proudest possessions.

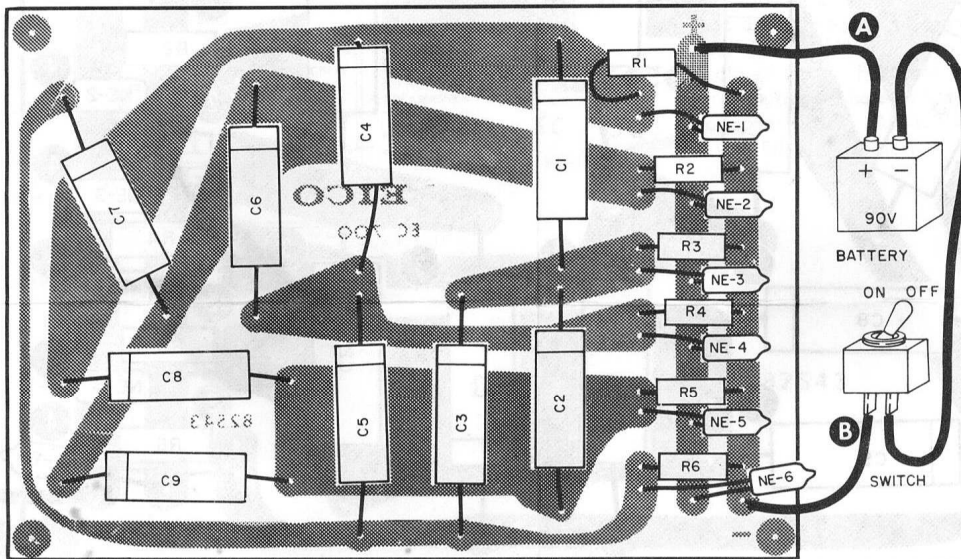

Figure 4. External Circuitry

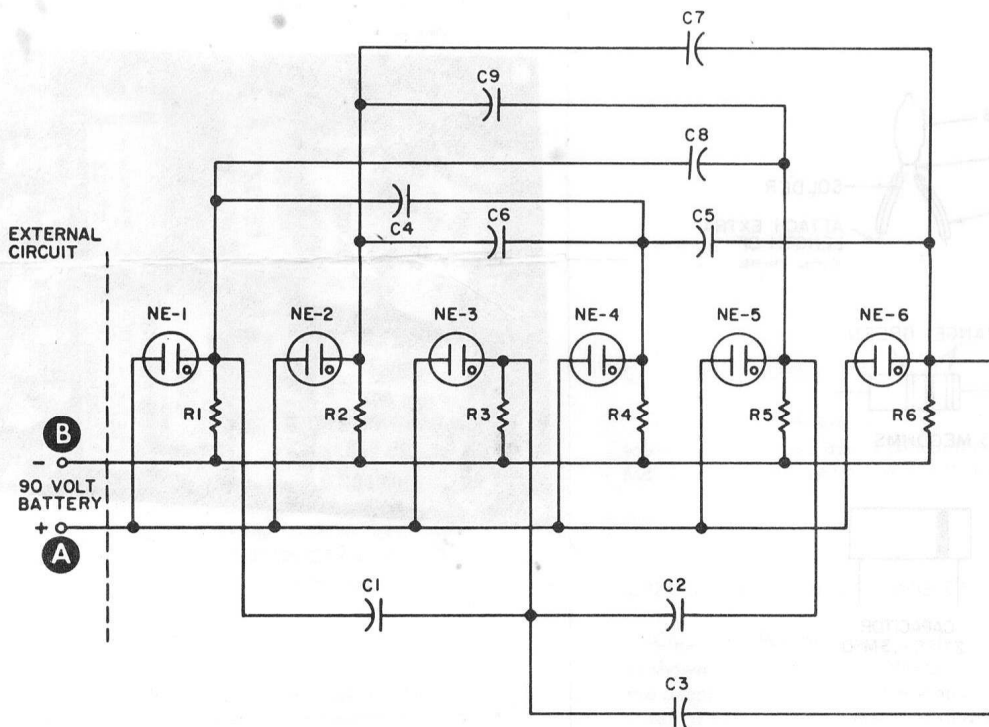

Figure 5. Schematic Diagram